



# RAMMER - ETR50H

# ETR50H

**Compact & lightweight yet a proven performer. Use in tight areas and for narrow trench compaction applications**



**Fully welded all steel handle** protects the top and sides of the engine. The padded replaceable grip provides the operator with an added level of comfort and vibration isolation.



**Fuel system** heavy duty poly tank with leak proof vented cap, and triple fuel filtration to guard against fuel contamination and engine breakdowns



**Handle rollers** help with loading and unloading, made of a heavy duty solid composite, and not prone to flexing or breaking



**Rammer foot** is made of laminated wood to reduce operator shock, with a thick metal bottom for long lasting wear. One of the most durable rammer shoes in the industry



**Lower engine guard** protects both the crankcase and engine recoil in instances when rammers are thrown in the bed of a truck and buried under loose gear.



**Lower leg sight glass** allows the operator to check the oil at a glance. Maintenance and service time is greatly reduced



**Throttle assembly** is a heavy-duty rack and pinion design made out of cast aluminum, no stamped metal parts to bend on you while you operate the throttle.

## Technical Data

MODEL	ETR50H
DIMENSION (LxWxH) - in (mm)	28.8 x 15.3 x 40.1 (733 x 390 x 1,022)
OPERATING WEIGHT - lbs (kg)	121 (55)
SHOE SIZE (LxW) - in (mm)	13.1 x 10.8 (333 x 275)
STROKE - in (mm)	2.8 (70)
IMPACT FORCE - lb (kg)	2,205 (1,000)
BLOWS PER MINUTE	600 - 650
TRAVEL SPEED - ft/min (m/min)	32.8 - 42.7 (10 - 13)
COMPACTED AREA - ft <sup>2</sup> /h (m <sup>2</sup> /h)	2,799 (260)
FUEL TANK CAPACITY - gal (ltr)	0.8 (3)
ENGINE	HONDA GX100
ENGINE TYPE	4-STROKE GASOLINE
MAX. POWER OUTPUT - kW (hp)	GX100 @ 2.1 (2.8)

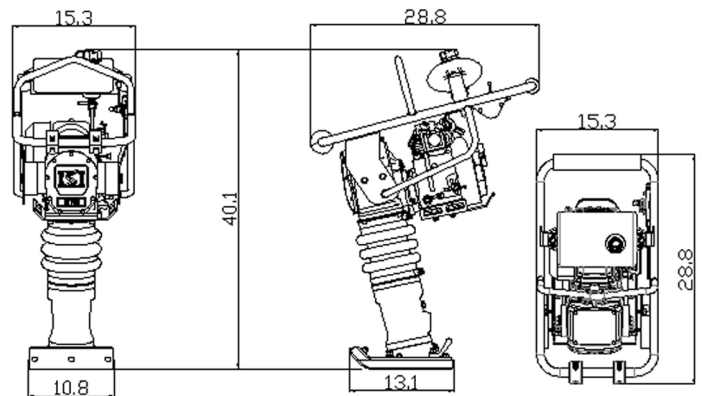

**Equipment Synergy International**  
 101 Gannaway Drive , Suite # 3  
 P.O. Box 997  
 Jamestown, North Carolina 27282  
 Phone: 866.648.7101  
 Fax: 336.310.1177  
 Email: sales@theESchoice.com  
 www.theESchoice.com